

Temperature transmitter with direct connection on terminal block

TM 50



KEY POINTS

- Transmitter with stainless steel contact tip (according to model)
- Measuring ranges from -20 to +80°C
- Connection on terminal block, 2 or 3 wires output
- ABS housing, IP65 or IP20 protection
- “¼ turn” system mounting with wall-mount plate
- Housing with simplified mounting system

FEATURES OF THE HOUSING

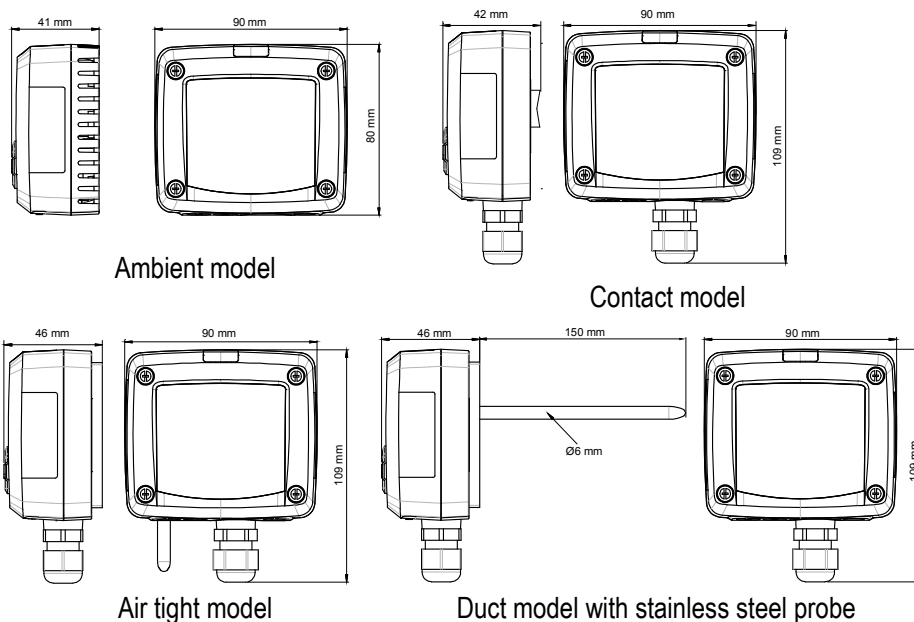

Material: ABS V0 as per UL94

Protection: IP20 (ambient model), IP65 (air tight, duct, and contact)

Cable gland: For cables Ø8 mm maximum

Weight: 143 g

Operating temperature: from -20 to +80°C

Storage temperature: from -20 to +80°C

TECHNICAL FEATURES

Measuring range	From -20 to +80°C
Accuracy*	Pt100
Type of sensor	Pt100 Class A
Contact tip (duct and air tight models)	Stainless steel 316L, without welding from 3/4 to 4/4 hard
Environment	Air and neutral gases

*All the accuracies indicated in this technical datasheet were stated in laboratory conditions, and can be guaranteed for measurements carried out in the same conditions, or carried out with calibration compensation.

PART NUMBER

- **TM50-S:** Ambient temperature transmitter type TM50-S. ABS wall housing. Pt100 2 / 3 wires output.
- **TM50-E:** Air tight temperature transmitter type TM50-E. ABS wall housing. Pt100 2 / 3 wires output.
- **TM50-AI:** Duct mount temperature transmitter type TM50-AI. ABS wall housing with stainless steel contact tip diameter 6 mm and length 150 mm. Pt100 2 / 3 wires output.
- **TM50-C:** Contact temperature transmitter type TM50-C. ABS wall housing. Pt100 2 / 3 wires output.

CONNECTIONS

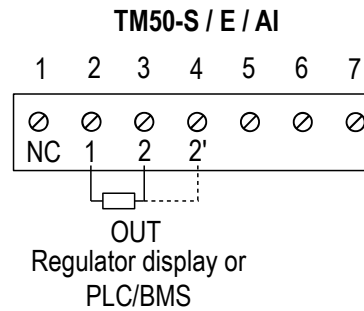
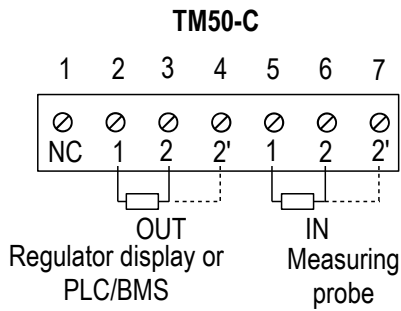

USEFUL INFORMATION ON THERMOMETRY WITH PLATINUM RESISTOR PT100

• 2-wire mounting

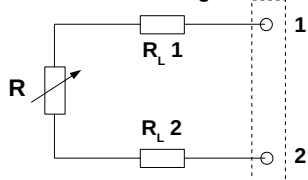

This is the simplest way, but line resistors (RL1 and RL2) are connected to the sensor in a series circuit. The addition of RL1 + RL2, leads to an off-set between measured temperature and real temperature. This connection must be avoided.

• 3-wire mounting

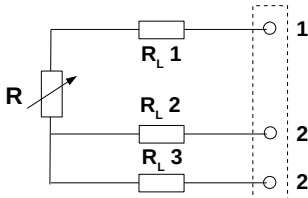

This connection involves identical line resistors (RL1-RL2-RL3), RL2 + RL3 allow you to measure the line resistance that will be subtracted from the measured resistance between 1 and 2-2' terminals. This is the most common connection.

MOUNTING

To mount the transmitter, mount the ABS plate on the wall (drilling: $\varnothing 6$ mm, screws and pins are supplied). Insert the transmitter on the fixing plate (see A on the drawing beside). Rotate the housing in clockwise direction until you hear a "click" which confirms that the transmitter is correctly installed.



Ambient model has not any fixing plate.

4 fixing holes are inside the back housing. Use them to install the transmitter on the required location.

The contact model is fixed with 2 mounting brackets supplied with the transmitter.

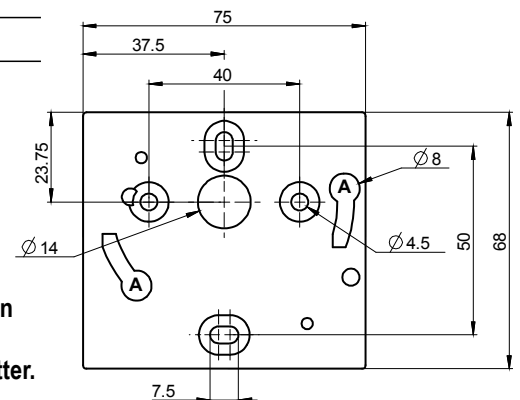

TOLERANCE OF PT100 PROBES AS PER IEC 751 (1993) STANDARD

Temperature °C	Tolerances	
	Class A	
	±°C	±°Ohms
-50	0.25	0.1
0	0.15	0.06
100	0.35	0.13

MAINTENANCE

Please avoid any aggressive solvent. Please protect the transmitter and its probes from any cleaning product containing formalin, that may be used for cleaning rooms or ducts.

OPTIONS AND ACCESSORIES

- Pt100 temperature probes



Once returned to KIMO, required waste collection will be assured in the respect of the environment in accordance with European guidelines relating to WEEE.

www.kimo.fr

Distributed by :



EXPORT DEPARTMENT

Tel : + 33. 1. 60. 06. 69. 25 - Fax : + 33. 1. 60. 06. 69. 29

e-mail : export@kimo.fr